



HAL
open science

Atmospheric Chemistry on Venus: An Overview of Unresolved Issues

F P Mills, Emmanuel Marcq, Y Yung, C D Parkinson, K L Jessup, A C Vandaele

► **To cite this version:**

F P Mills, Emmanuel Marcq, Y Yung, C D Parkinson, K L Jessup, et al.. Atmospheric Chemistry on Venus: An Overview of Unresolved Issues. 50th Lunar and Planetary Science Conference, Mar 2019, The Woodlands, United States. pp.LPI Contribution No. 2132, id.2374. insu-04476097

HAL Id: insu-04476097

<https://insu.hal.science/insu-04476097v1>

Submitted on 24 Feb 2024

HAL is a multi-disciplinary open access archive for the deposit and dissemination of scientific research documents, whether they are published or not. The documents may come from teaching and research institutions in France or abroad, or from public or private research centers.

L'archive ouverte pluridisciplinaire **HAL**, est destinée au dépôt et à la diffusion de documents scientifiques de niveau recherche, publiés ou non, émanant des établissements d'enseignement et de recherche français ou étrangers, des laboratoires publics ou privés.

ATMOSPHERIC CHEMISTRY ON VENUS: AN OVERVIEW OF UNRESOLVED ISSUES. F. P. Mills^{1,2}, E. Marcq³, Y. Yung⁴, C. D. Parkinson⁵, K. L. Jessup⁶, and A. C. Vandaele⁷, ¹Fenner School of Environment and Society, Australian National University, Canberra, ACT, Australia, ²Space Science Institute, Boulder CO, USA, ³Laboratoire Atmosphères, Milieux, Observations Spatiales, Université de Versailles, Guyancourt, France, ⁴Division of Geological and Planetary Sciences, California Institute of Technology, Pasadena, CA, USA, ⁵University of Michigan, Ann Arbor, MI USA, ⁶Southwest Research Institute, Boulder CO, USA, ⁷Royal Belgian Institute for Space Aeronomy, Brussels, Belgium.

Introduction: Venus' atmosphere is 96.5% CO₂ and 3.5% N₂ with trace abundances of SO₂, OCS, H₂O, HCl, HF, and HBr, as well as their photochemical and lightning-induced products. The global clouds are composed at least partly of concentrated sulfuric acid. The surface pressure is 90 atm and surface temperatures exceed 700 K. Atmospheric chemistry transitions from ion chemistry through photochemistry to thermal equilibrium chemistry with heterogeneous chemistry likely throughout the atmosphere.

Current understanding: Three major chemical cycles have been identified: the carbon dioxide, sulfur oxidation, and polysulfur cycles [e.g., 1], Fig. 1. The carbon dioxide cycle includes CO₂ photolysis, transport of a significant fraction of CO and O to the night side, production of O₂, and conversion of CO and O₂ to CO₂, mostly via chlorine catalyzed pathways. The sulfur oxidation cycle comprises transport upward of OCS, SO₂, and H₂O, oxidation to H₂SO₄, condensation to form the global 30-km thick cloud layers, and sulfuric acid rain. The polysulfur cycle involves the upward transport of OCS and SO₂, disproportionation and production of S_x (x=2-8), and downward transport of S_x to react with CO and SO₃. There is solid evidence for the carbon dioxide and sulfur oxidation cycles; the polysulfur cycle is more speculative but plausible. Alternatively, sulfur chemistry on Venus has been conceptually divided into fast and slow atmospheric cycles and a geological cycle [e.g., 2,3,4]. Recent work suggests the ternary SO₂-H₂O-H₂SO₄ system may bifurcate depending on the relative abundances of H₂O and SO₂ [5].

Key outstanding issues: Despite this general understanding, five decades of spacecraft observations, and 200 years of Earth-based observations, numerous significant unresolved issues remain. One is the means by which CO₂ is stabilized over geologic time - models predict abundances a factor of 10 larger than the observational upper limit [e.g., 6,7]. Another is the lack of consistency among models of the chemistry and microphysics in different regions, especially in the cloud layers, where the mixing ratios of many important trace species change by orders of magnitude within several vertical scale heights, and at the surface [2]. A third is the mechanism(s) creating an inversion layer in SO₂ abundances in the mesosphere, Fig. 2.

References: [1] Mills F. P. et al. (2007) *Exploring Venus as a Terrestrial Planet*, 73-100. [2] Marcq E. et al. (2018) *Space Sci. Rev.* 214, 10. [3] Krasnopolsky V. A. (2013) *Icarus*, 225, 570-580. [4] Krasnopolsky V. A. (2012) *Icarus*, 218, 230-246. [5] Parkinson C. D. (2015) *Planet. Space Sci.*, 113-114, 226-236. [6] Mills and Allen (2007), *Planet. Space Sci.*, 55, 1729-1740. [7] Krasnopolsky V. A., *Planet. Space Sci.*, 54, 1352-1359.

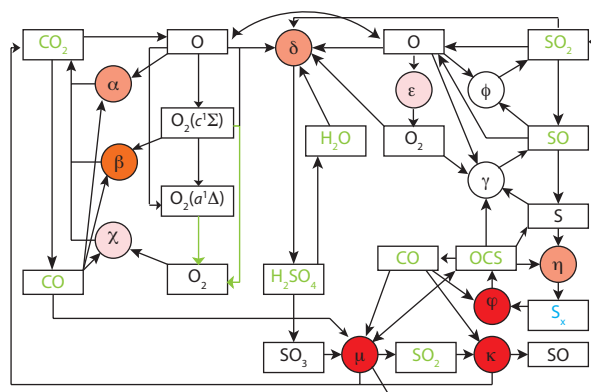

Fig. 1. Schematic diagram for the atmospheric chemistry on Venus. Catalytic schemes are indicated by the Greek letters in circles. The degree of laboratory confirmation is indicated by the lightness of the shade of red. The darkest red have received no confirmation. (After [1].)

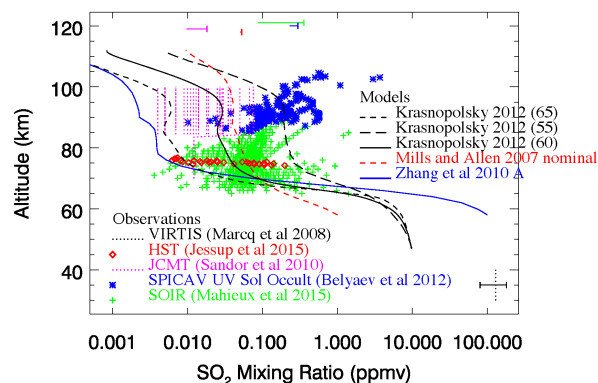

Fig. 2. Observed and modeled SO₂ (after [2]). Only models using standard chemistry are shown.